

- 6=5/16X1 BOLTS-A
- 16=5/16 USS WASHERS-B
- 10=5/16 LOCK NUTS-C
- 2=5/16X1 1/2U-BOLTS-D
- 2=1/4X3/8 U-BOLTS-E
- 4=1/4 LOCK NUTS-F
- 4=1/4 USS WASHERS-G
- 4=1 1/2 PLUGS-H

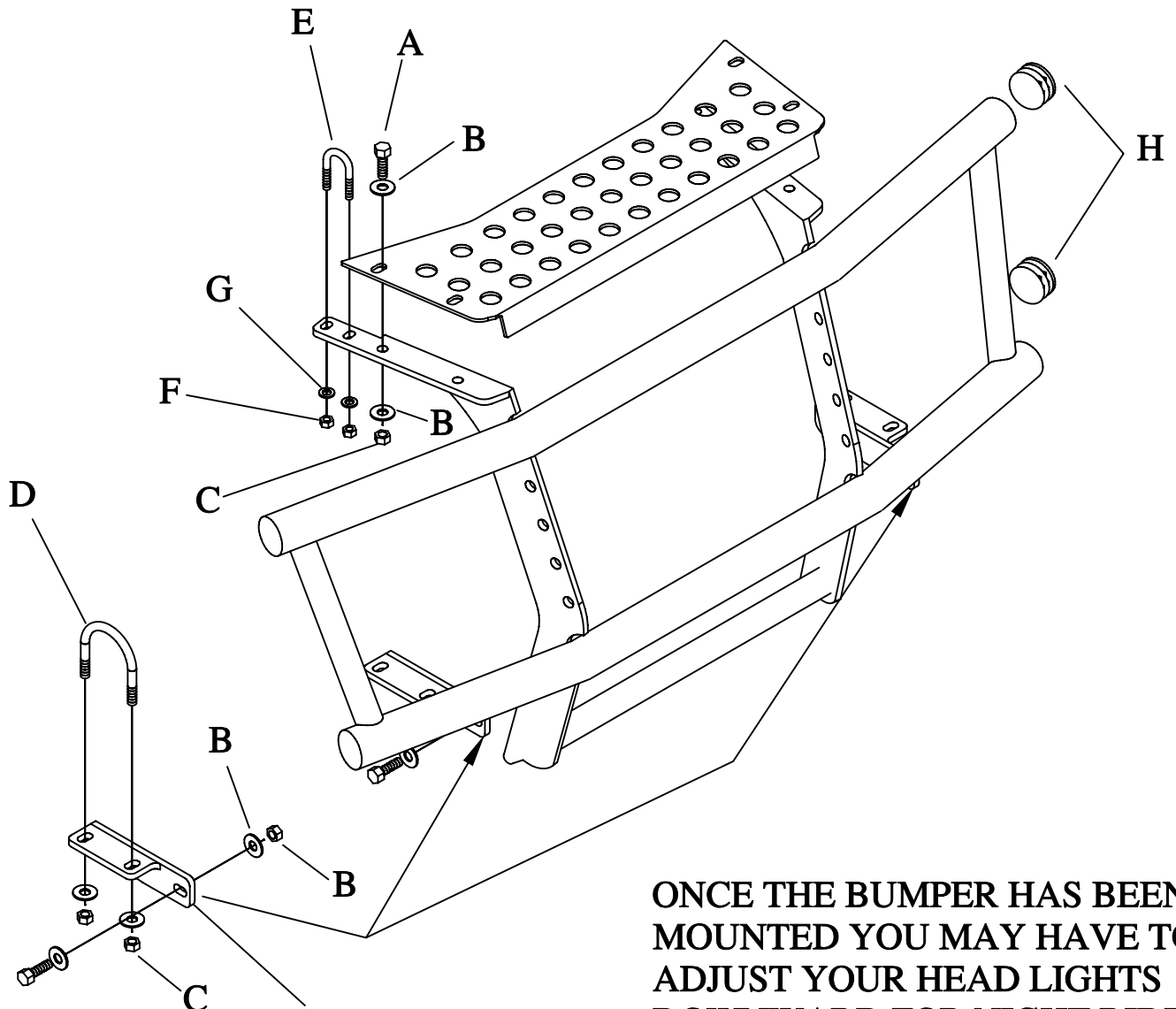

# #BG-14

## KAWASAKI 700 BUMPER



THESE BRACKETS WILL BOLT TO THE ORIGINAL BUMPER PIPE.

ONCE THE BUMPER HAS BEEN MOUNTED YOU MAY HAVE TO ADJUST YOUR HEAD LIGHTS DOWNWARD FOR NIGHT RIDING. THEIR SHOULD BE A SCREW ON THE BACK OF THE HEADLIGHTS FOR THIS ADJUSTMENT.