

4=1/2 X 1 WING BOLTS-A
4=7/16 USS WASHERS-B
2=1/4 X 1 BLACK TORX
HEAD SCREWS-C



IF DESIRED BY INSTALLER THEY
MAY DRILL THESE HOLES TO A 5/16
HOLE AND USE A 5/16 X 3" BOLTS
WITH 5/16 SAE WASHERS AND 5/16
LOCK NUTS TO MOUNT THE PLATE
TO THE STOCK BUMPER.

BG-29W

YAMAHA RHINO 660 450 FRONT BUMPER

REMOVE THE STOCK
PLASTIC MIDDLE GUARD
USE THE SAME STOCK
BOLTS AND INSTALL THE
MAIN BRACKET.

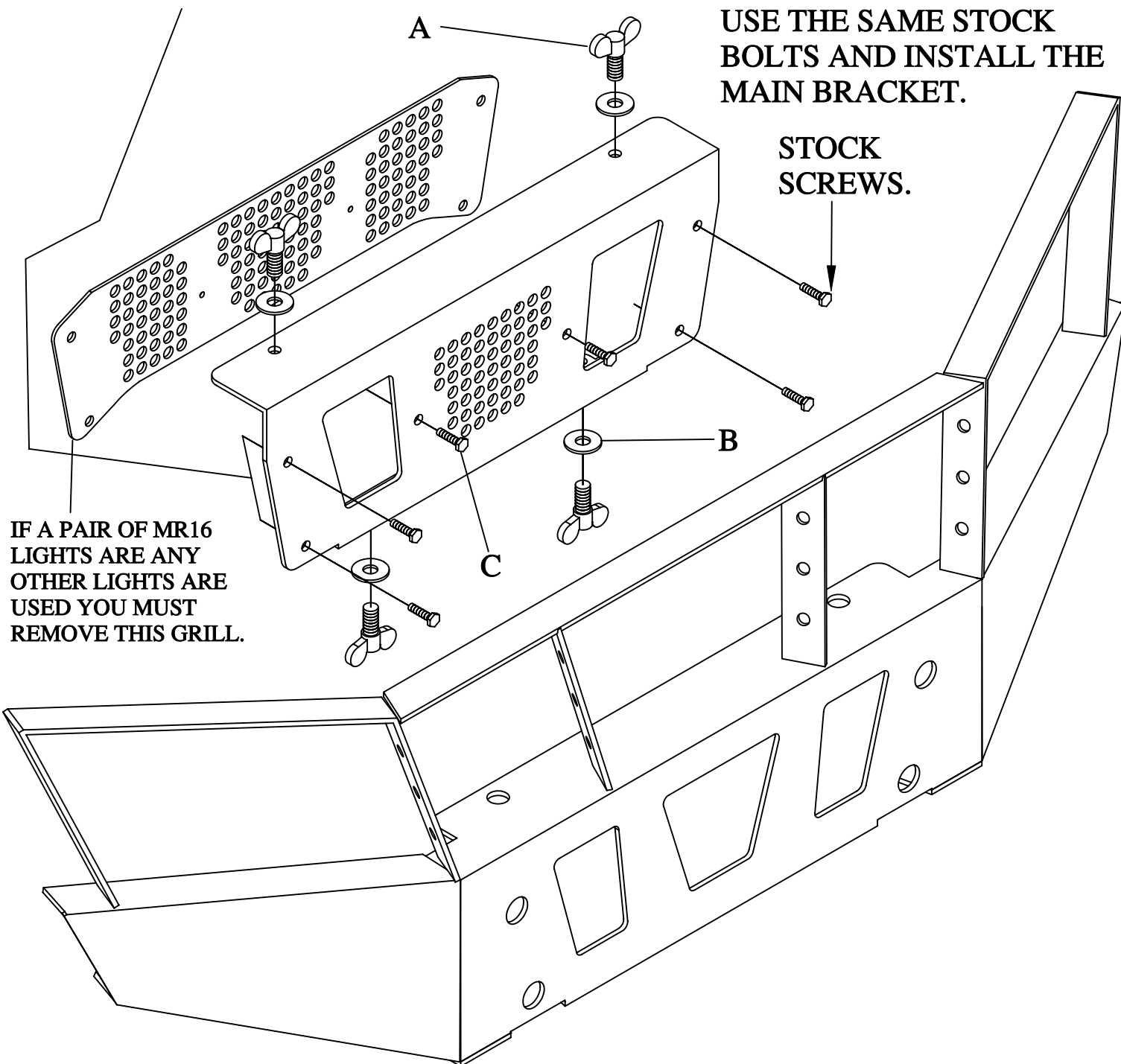

STOCK
SCREWS.

IF A PAIR OF MR16
LIGHTS ARE ANY
OTHER LIGHTS ARE
USED YOU MUST
REMOVE THIS GRILL.