



# # 567

## POLARIS XP550 / 850 2009'S

- 2=7/8" GALV. SPACERS-A
- 6=7/16" GALV. SPACERS-B
- 2=1/4 X 2 1/2" BOLTS-C
- 6=1/4 X 2 1/4" BOLTS-D
- 8=1/4 LOCK NUTS-E
- 16=1/4 USS WASHERS-F
- 2=1" PLUGS-G
- 2=5/16 LOCK NUTS-H
- 4=5/16 USS WASHERS-I
- 2=5/16 X 2 BOLTS-J
- 2=5/16 X 1 1/2" BOLTS-K

**MUST REMOVE THE BLACK TORX SCREWS FROM THE SIDES OF THE RACK TO INSTALL THE PLATE BRACKETS.**

**Caution: DO NOT USE AIR TOOLS to install, may result to injury.**

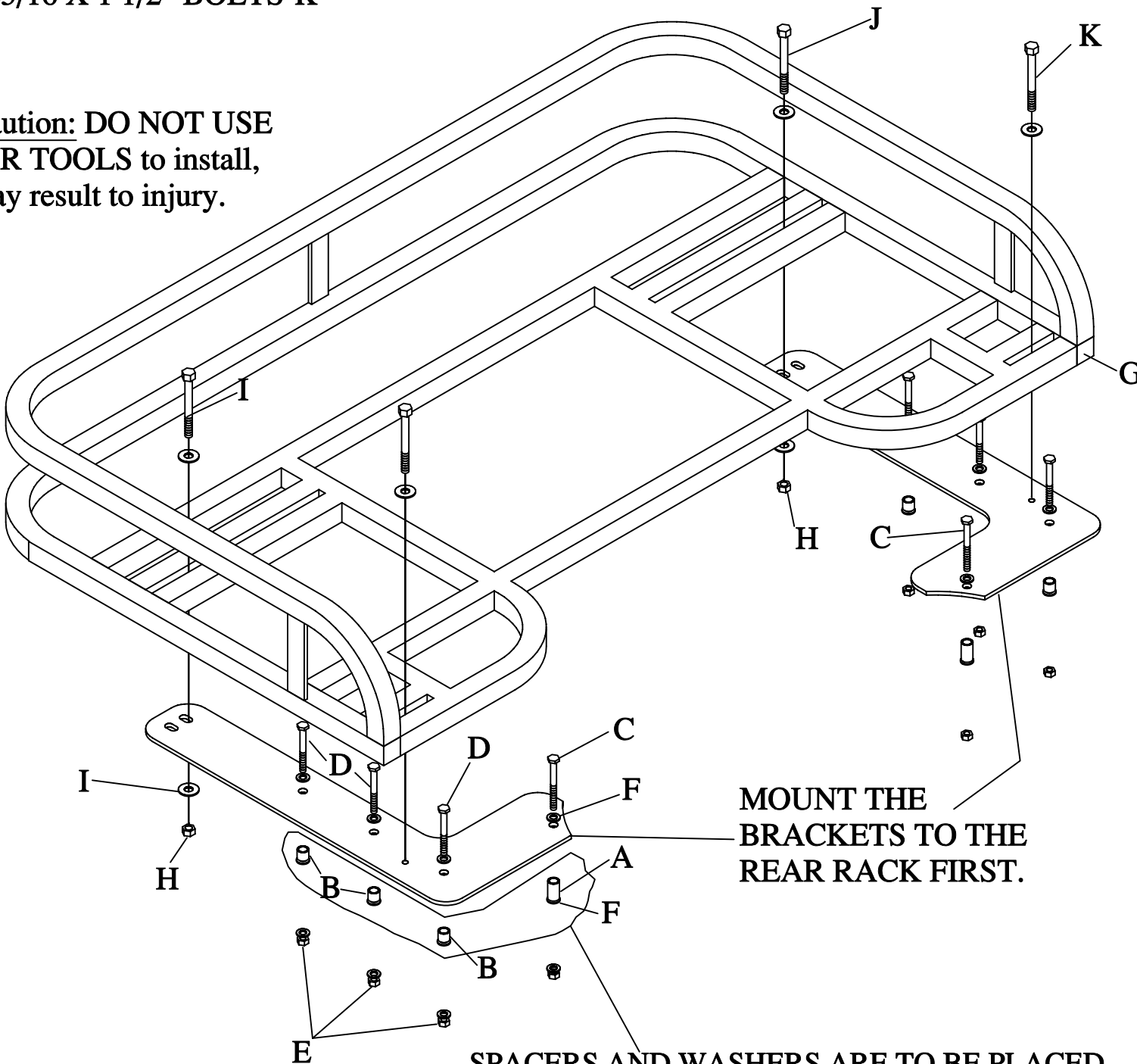

**MOUNT THE BRACKETS TO THE REAR RACK FIRST.**

**SPACERS AND WASHERS ARE TO BE PLACED UNDER THE PLATE BETWEEN THE BRACKET AND THE STOCK PLASTIC RACK.**