

- 8=Gr. 5 (5/16) USS WASHERS-A
- 4=5/16 X 1 1/2 BOLTS -B
- 2=1" PLUGS-C
- 6=5/16 X 3 1/2 FLAT HEAD COUNTERSINK BOLTS-D
- 2=5/16 U NUT CLIPS-E



569-BO'S

569

2011 POLARIS SPORTSMAN REAR RACK

MAKE SURE THE COUNTERSINK HOLES A FACING UP WHEN MOUNTING TO THE FACTORY RACK.

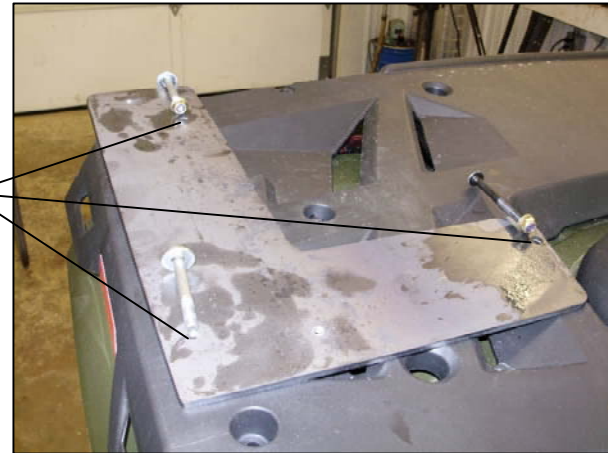

PLACE THE 569 BRACKETS ONTO THE REAR RACK. WILL HAVE TO REMOVE THE STOCK BOLTS ON THE REAR RACK WHERE THE HOLES FALL. CAUTION: THERE IS SPACERS UNDER THE RACK ON TOP OF THE FENDER MUST USE THESE TO MOUNT BRACKETS. REPLACE THE STOCK BOLTS WITH THE SUPPLIED COUNTERSINK BOLTS. REFER TO DRAWING FOR BOLT PLACEMENT.

ONCE THE BRACKETS ARE MOUNTED TO THE ORIGINAL RACK. PROCEED TO MOUNT THE RACK TO THE BRACKETS WITH SUPPLIED HARDWARE. REFER TO THE DRAWING FOR BOLT PLACEMENT.

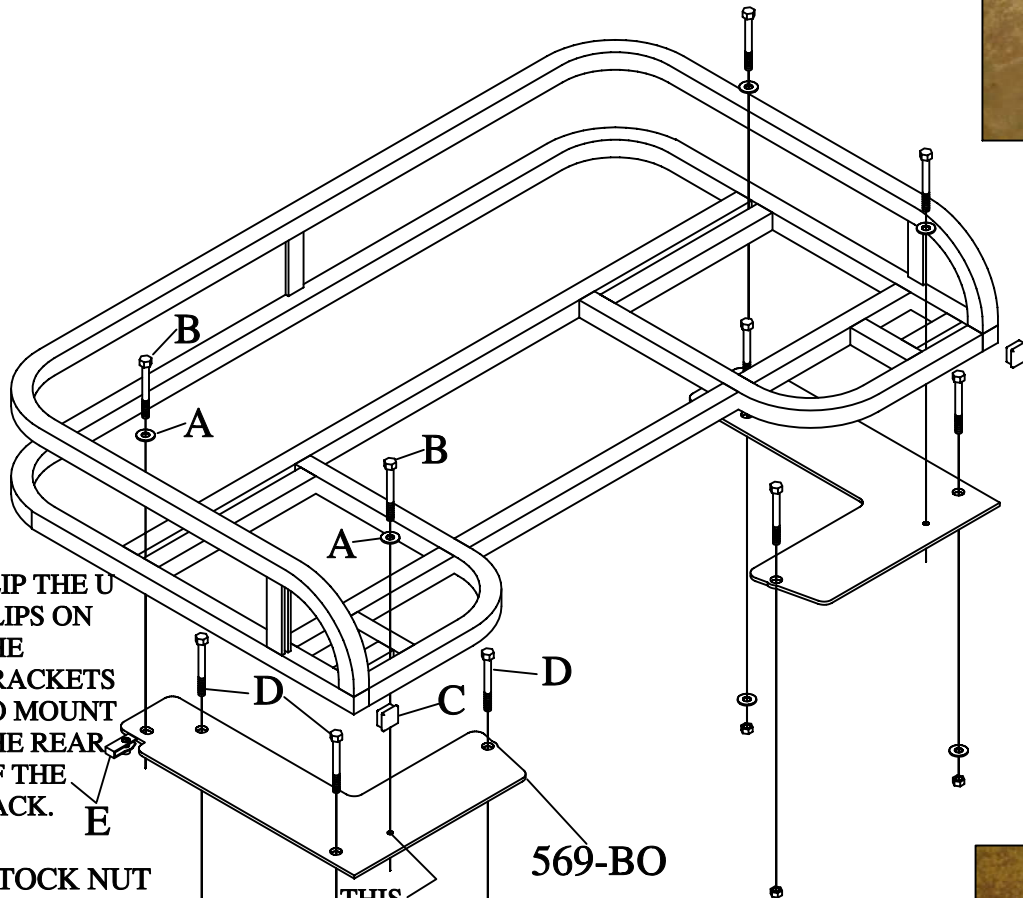

SLIP THE U CLIPS ON THE BRACKETS TO MOUNT THE REAR OF THE RACK.

STOCK NUT THAT WAS REMOVED MUST REUSE.

THIS HOLE IS THREADED.

STOCK NUT THAT WAS REMOVED MUST REUSE.

