

- 6=1/4 X 1/2 U-BOLTS-A
- 6=#16 TANNER RIVETS-B
- 6=5/16 SAE WASHERS-C
- 2=3/16 X 1 X 3/8 ZINC WASHER-D
- 2=5/16 X 2 1/4 BOLTS-E
- 4=5/16 USS WASHERS-F
- 12=1/4 LOCK NUTS-G
- 12=1/4 SAE WASHERS-H
- 2=5/16 LOCK NUTS-I

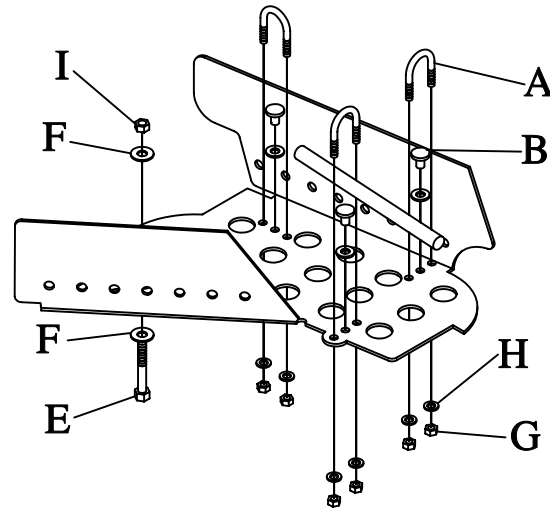

SS160H

REAR STICK STOPPERS FOR
ARCTIC CAT PROWLER 650



THE RIVETS (B) WASHERS (C) AND 3/16 X 1 WASHERS (D) ARE USED AS SPACERS.

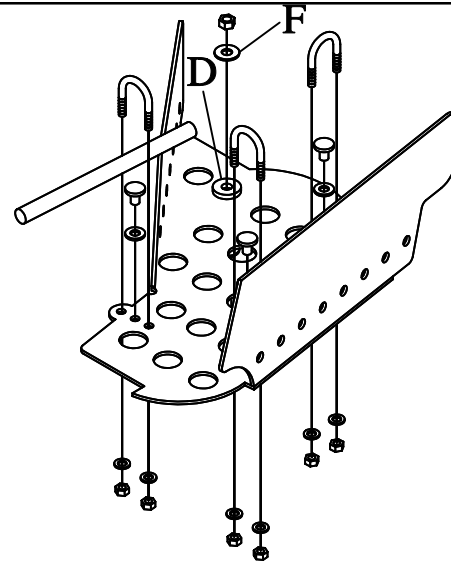

THE SS160H WILL BOLT AS SHOWN ON PIC.

THIS END HERE WILL FACE THE INSIDE OF THE FRAME ONCE THEY HAVE BEEN MOUNTED.

