



- 12 = 1/4 LOCK NUTS-A
- 12 = 1/4 SAE WASHERS-B
- 6 = 5/16 SAE WASHERS-C
- 6 = 1/4 X 1/2 U-BOLTS-D
- 6 = #16LB TINNER RIVETS-E

SS170H

HONDA RANCHER 420 4X4 2007

REMOVE THE PLASTIC A-ARM GUARD FROM THE ARMS. LEAVING THE SMALLER PLASTIC GUARDS COVERING THE OUTER CV BOOTS. DO NOT REMOVE THE SMALLER GUARDS THAT ARE BOLTED ON THE BEARING KNUCKLES.

THESE BARS REPRESENT THE A-ARMS OF THE ATV.

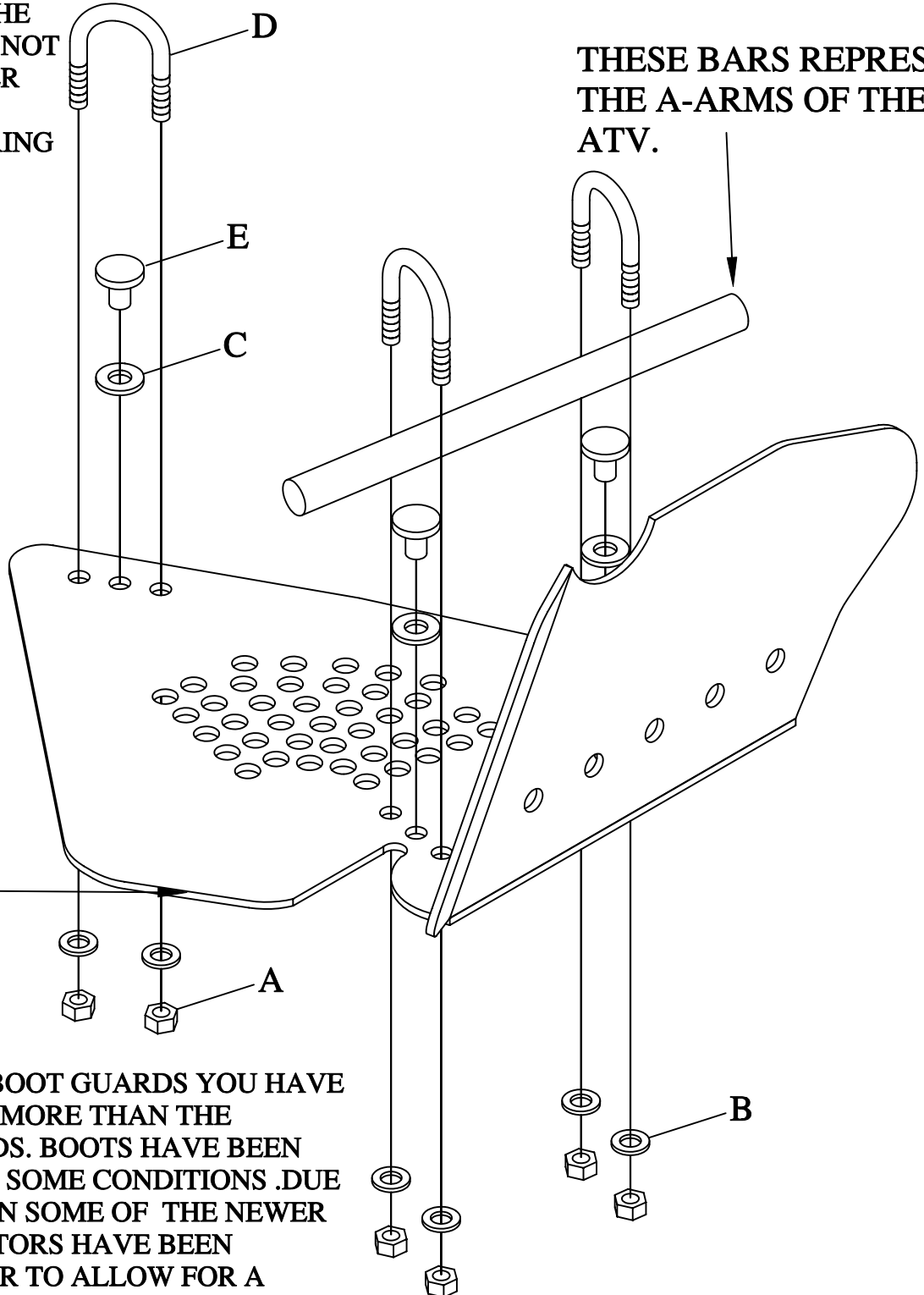

ONCE MOUNTED UNDER THE A-ARMS OF THE ATV THIS END WILL FACE THE INSIDE OF THE RIM.

EVEN THOUGH THE NEW BOOT GUARDS YOU HAVE PURCHASED WILL COVER MORE THAN THE ORIGINAL PLASTIC GUARDS. BOOTS HAVE BEEN REPORTED TO BE TORN IN SOME CONDITIONS .DUE TO THE TURNING RADIUS ON SOME OF THE NEWER ATV'S. THE BOOT PROTECTORS HAVE BEEN MANUFACTURED SMALLER TO ALLOW FOR A TIGHTER TURNING RADIUS. SAVANT MFG. (STRONG MADE) DOES NOT WARRANTY ANY TORN BOOTS.