

- 4=1/4 X 1 SQUARE U-BOLTS-A
- 4=#16 TANNER RIVETS-B
- 8=5/16 SAE WASHERS-C
- 8=1/4 LOCK NUTS-D
- 4=5/16 LOCK NUTS-E
- 4=5/16 X 1 BOLTS-F



SS186H

REAR 2008 SPORTSMAN 800 GUARDS

REMOVE THE STOCK PLASTIC GUARDS TO INSTALL THE NEW METAL GUARDS.

THIS IS THE SIDE YOU WILL SEE FROM LOOKING AT THE REAR OF THE MACHINE. THE GUARD WILL MOUNT UNDER THE A-ARM OF THE UNIT.

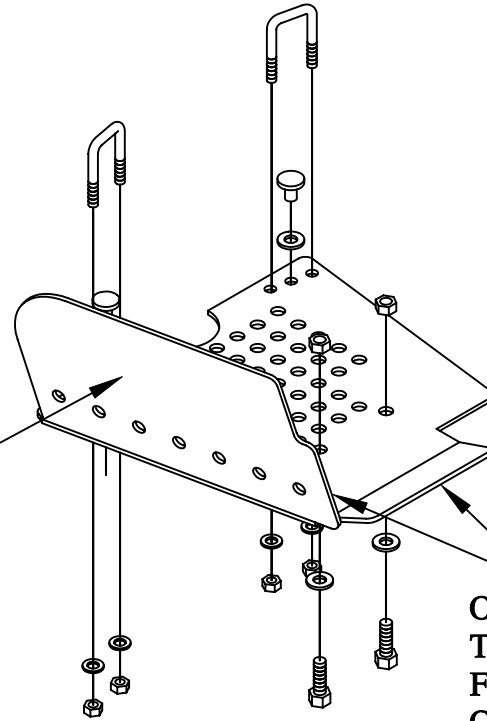

ONCE MOUNTED THIS END WILL FACE THE INSIDE OF THE RIM.

THE MOUNTING OF THE GUARDS ARE MUCH EASIER IF THE WHEELS ARE REMOVED.

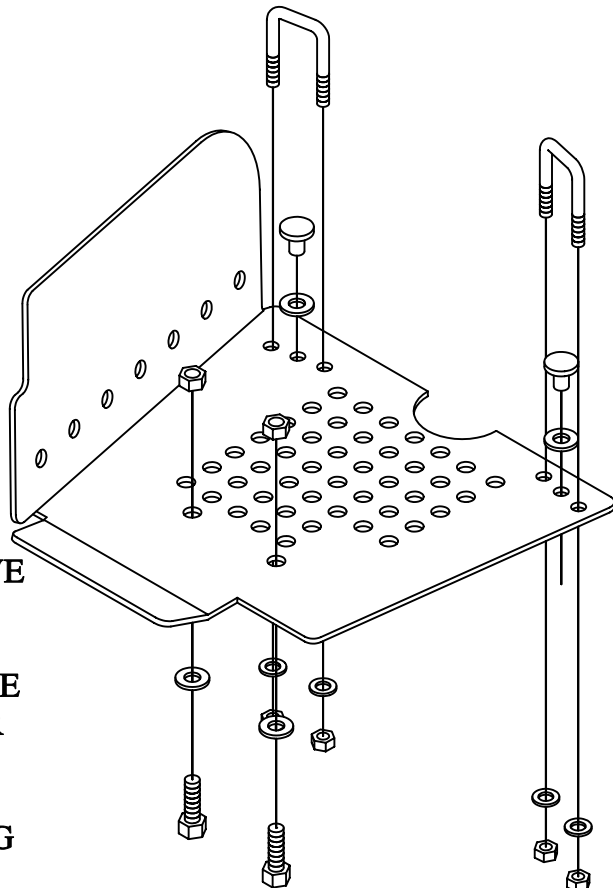

EVEN THOUGH THE NEW BOOT GUARDS YOU HAVE PURCHASED WILL COVER MORE THAN THE ORIGINAL PLASTIC GUARDS. BOOTS HAVE BEEN REPORTED TO BE TORN IN SOME CONDITIONS .DUE TO THE TURING RADIUS ON SOME OF THE NEWER ATV'S. THE BOOT PROTECTORS HAVE BEEN MANUFACTURED SMALLER TO ALLOW FOR A TIGHTER TURING RADIUS. SAVANT MFG. (STRONG MADE) DOES NOT WARRANTY AND TORN BOOTS.